

**Code No: 151AD****JAWAHARLAL NEHRU TECHNOLOGICAL UNIVERSITY HYDERABAD****B.Tech I Year I Semester Examinations, July - 2021****ENGINEERING GRAPHICS****(Common to CE, ME, EIE, MCT, MMT, ECM, AE, MIE, PTM, CSBS, CSE(AIML),  
CSE(IOT))****Time: 3 hours****Max. Marks: 75****Answer any three questions  
All questions carry equal marks**

- - -

- 1.a) The distance between two stations is 100 km and on a road map, it is shown by 30 cm. Draw a diagonal scale and indicate distances of 46.8 km, 71.9 km and 32.4 km on it.
- b) The asymptotes of a hyperbola are inclined at  $105^{\circ}$  to each other. A point P on the curve is 40 mm and 50 mm from the asymptotes respectively. Construct two branches of the hyperbola and determine distance between its vertices, distance between its directrices, distance between its foci and eccentricity. [10+15]
- 2.a) Draw the projection of two points on the same reference line, point A being 20 mm above HP and 50 mm behind VP and point B being 25 mm below HP and 40 mm behind VP.
- b) A line PQ inclined at  $45^{\circ}$  to the V.P. and has a 60 mm long front view. The end P is 10 mm from both the principal planes while end Q is 45 mm above HP. Draw the projections of the line and determine its true length and inclinations with the principal planes. [10+15]
3. An isosceles triangular plane ABC with a 70 mm base and altitude 80 mm has its base in the HP and inclined at  $45^{\circ}$  to the VP. The corners A and C are in the VP. Draw its projections and determine the inclination of the plane with HP. [25]
4. A cone with base 60 mm diameter and 70 mm long axis rests on one of its generators in the HP with its axis parallel to VP. It is cut by an AIP inclined at  $60^{\circ}$  to HP, bisecting the axis. Draw its sectional top view and true shape of the section. [25]
5. A cylinder with base circle diameter 50 mm and 60 mm height is resting on the base in HP. It is cut by a plane perpendicular to VP and 60 degrees inclined to HP and bisecting the axis of the solid. Draw development of lateral surface of the bottom part of the solid. [25]

6. Draw the orthographic projections of front view, top view and right side view in the first angle projection of the following solid as shown in figure. (All dimensions are in mm). [25]

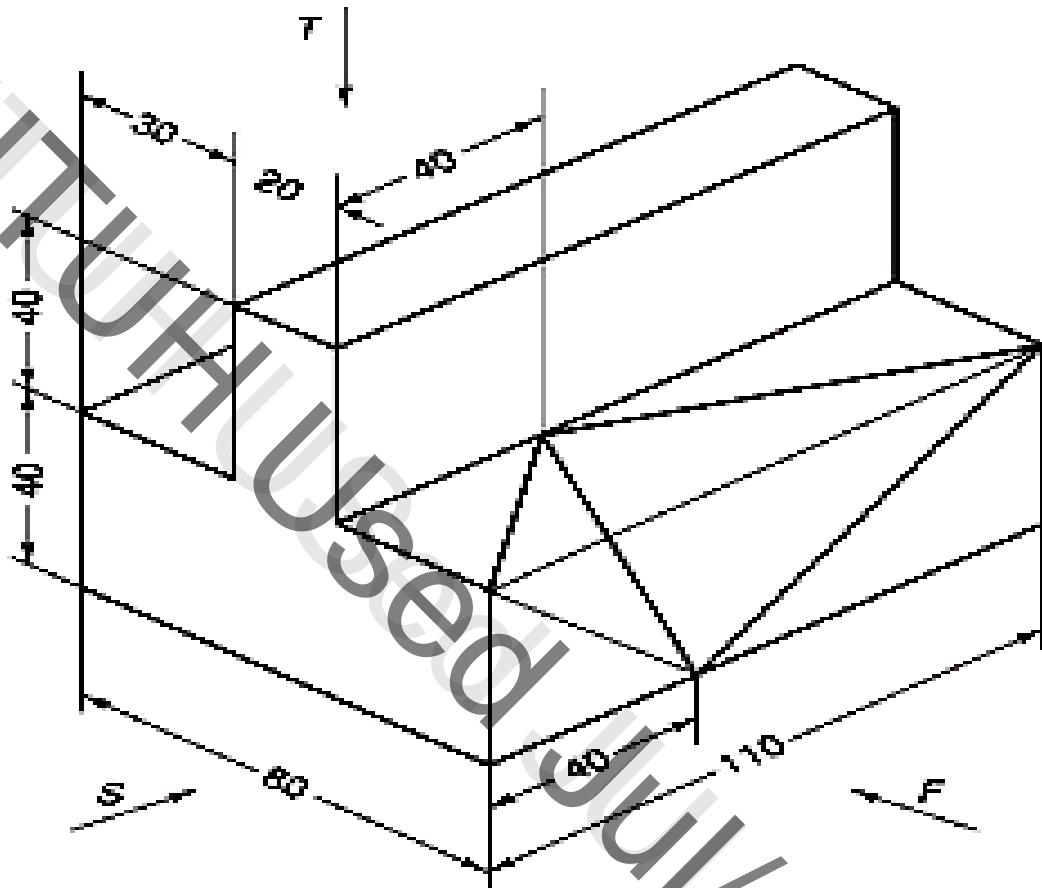

---ooOoo---