

Code No: 182AA

JAWAHARLAL NEHRU TECHNOLOGICAL UNIVERSITY HYDERABAD

B. Tech I Year II Semester Examinations, September - 2023

APPLIED MECHANICS

(Civil Engineering)

Time: 3 Hours

Max. Marks: 60

**Note:** This question paper contains two parts A and B.

i) **Part- A** for 10 marks, ii) **Part - B** for 50 marks.

- Part-A is a compulsory question which consists of ten sub-questions from all units carrying equal marks.
- Part-B consists of **ten questions** (numbered from 2 to 11) **carrying 10 marks each**. From each unit, there are two questions and the student should answer one of them. Hence, the student should answer five questions from Part-B.

**PART- A****(10 Marks)**

- |      |   |     |
|------|---|-----|
| 1.a) | What are coplanar forces?                   | [1] |
| b)   | Give an example of a couple.                | [1] |
| c)   | What is ladder friction?                    | [1] |
| d)   | Express pappus guldinus's first theorem.    | [1] |
| e)   | What is polar moment of inertia?            | [1] |
| f)   | Express centroid of an arc from the centre. | [1] |
| g)   | Express the range in projectile motion.     | [1] |
| h)   | What is curvilinear motion?                 | [1] |
| i)   | State principle of conservation of energy.  | [1] |
| j)   | What is fixed axis rotation?                | [1] |

**PART - B****(50 Marks)**

- 2.a) State and explain triangle law of force.
- b) Two forces are applied as shown to a hook support. Knowing that the magnitude of **P** is 35 N, determine by trigonometry (a) the required angle  $\alpha$  if the resultant **R** of the two forces applied to the support is to be horizontal, (b) the corresponding magnitude of **R**. (Figure 1) [3+7]

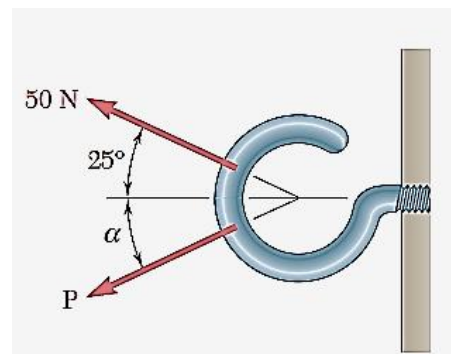

**Figure 1**  
**OR**

3. A transmission tower is held by three guy wires attached to a pin at  $A$  and anchored by bolts at  $B$ ,  $C$ , and  $D$ . If the tension in wire  $AB$  is  $3 \text{ kN}$ , determine the vertical force  $\mathbf{P}$  exerted by the tower on the pin at  $A$ .(Figure 2) [10]

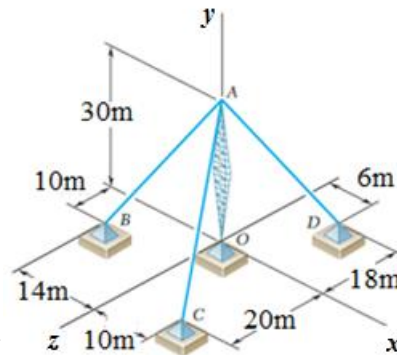

Figure 2

- 4.a) Give the classification of the types of friction.  
 b) A ladder 5 meters long rests on a horizontal ground and leans against a smooth vertical wall at an angle  $70^\circ$  with the horizontal. The weight of the ladder is  $900 \text{ N}$  and acts at its middle. The ladder is at the point of sliding, when a man weighing  $750 \text{ N}$  stands on a rung  $1.5 \text{ metre}$  from the bottom of the ladder. Calculate the coefficient of friction between the ladder and the floor. [3+7]

OR

- 5.a) Explain the implications of center of gravity.  
 b) Find the centroid,  $\bar{x}$  and  $\bar{y}$  from the axes.(Figure 3) [3+7]

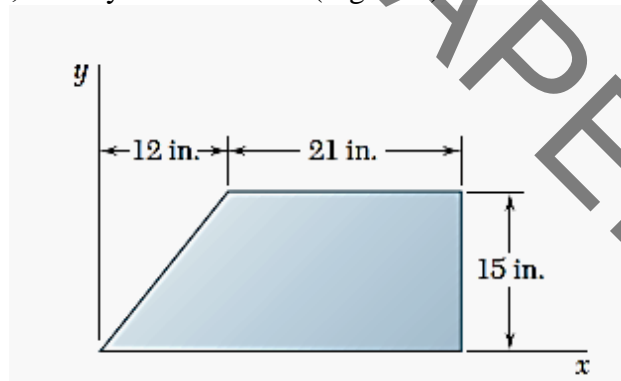

Figure 3

- 6.a) State perpendicular axis theorem for moment of inertia.  
 b) Find the Moment of inertia about diameter of the following composite lamina.(Figure 4) [3+7]

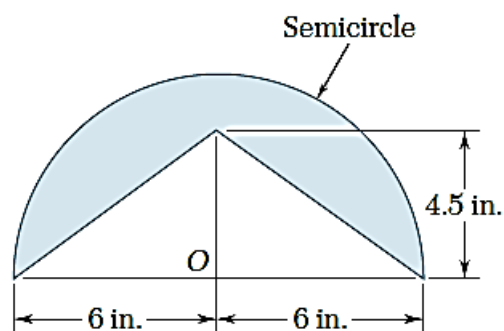

Figure 4

OR

- 7.a) Derive mass moment of inertia of the sphere about its centre.  
b) Find the mass moment of inertia of composite body consisting of cylinder (steel) and cone (Brass), resting on the top of the cylinder, about its base. Density of steel- $7850\text{kg/m}^3$  density of Brass- $8650\text{kg/m}^3$ . Cone axis height = 12 cm, cylinder height = 10 cm,  $r = 4\text{cm}$ . [5+5]
- 8.a) An automobile starting from the rest speeds up to 12 m/s with a constant acceleration of  $1.2\text{ m/s}^2$ , runs at this speed for a time, and finally comes to rest with a deceleration of  $1.5\text{ m/s}^2$ . If the total distance travelled is 366 m, find the total time required.  
b) A projectile is fired from the top of the cliff 100 m high with a velocity of 430 m/s directed at  $45^\circ$  to the horizontal. Find the range on a horizontal plane through the base of the cliff. [5+5]

OR

- 9.a) Find the acceleration of each body in the system as shown in figure 5. Weight of body B = 1350 N.

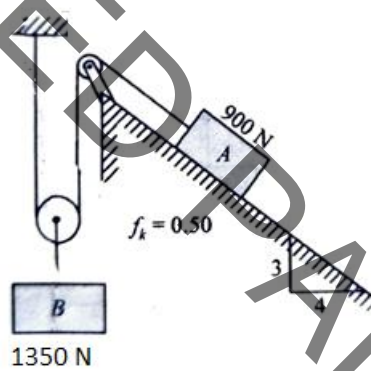

Figure 5

- b) A block of mass 10 kg slides over a frictionless horizontal plane with a constant velocity of 5 m/s. after some distance, the plane is inclined at an angle of  $20^\circ$  with the horizontal. Find the distance through which the block will slide upwards on the inclined plane before coming to rest. [5+5]
- 10.a) State and explain work energy principle.  
b) Determine the constant force P that will give the system of bodies a velocity of 3 m/s after moving 4.6 m from rest. Use work energy method.(Figure 6) [5+5]

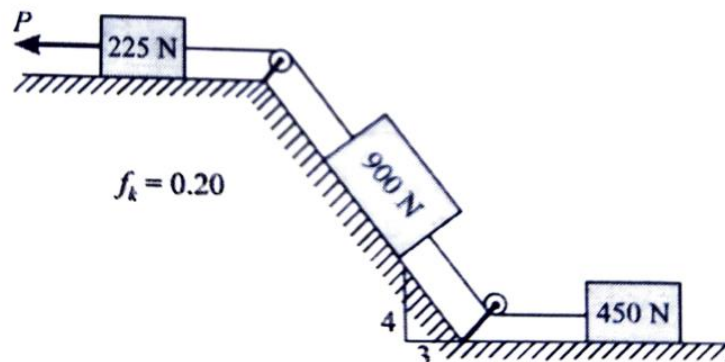

Figure 6

**OR**

11.a) Explain the importance of coefficient of restitution.

b) A 1 N ball is bowled to a batsman. The velocity of ball was 20 m/s horizontally just before batsman hit it. After hitting it went away with a velocity of 48 m/s at an inclination of  $30^\circ$  to horizontal. Find the average force exerted on the ball by the bat if the impact lasts for 0.02 sec. [3+7]

--ooOoo--

UNINTENDED PAPER S-2023