

Code No: 51015**JAWAHARLAL NEHRU TECHNOLOGICAL UNIVERSITY HYDERABAD****B.Tech I Year Examinations, June - 2022****ENGINEERING DRAWING****(Information Technology)****Time: 3 Hours****Max. Marks: 75****Answer any three questions****All questions carry equal marks**

- - -

- 1.a) Construct a Diagonal scale of $1\text{cm} = 2.5\text{ km}$, mark on it length 26.7 km .
b) Draw the locus of a point P moving so that the ratio of distance from a fixed point F to its distance from fixed straight line DD' is $3/4$. Point P is at distance of 70 mm from DD'. Also draw tangent and normal to the curve. [12+13]
- 2.a) A line AB measuring 75 mm long has one of its ends 50 mm in front of VP and 15 mm above HP. The top view of the line is 50 mm long. Draw and measure the front view. The other end is 15 mm in front of VP and is above HP. Draw the true inclinations and traces.
b) A line PQ 100 mm long is inclined at 30° to the H.P and at 45° to the V.P its midpoint is in V.P and 20 mm above the H.P. Draw its projections if its end P is in the third quadrant and Q in the first quadrant. [12+13]
- 3.a) A hexagonal plate of 30 mm is resting on one of its sides on VP and inclined at 40° to HP. Its surface is inclined at 35° to VP. Draw its projections.
b) Draw the projections of a cone base 75 mm diameter and axis 100 mm long, lying on the ground on one of its generators with the axis parallel to the V.P. [13+12]
- 4.a) A right circular cone 60 mm of base diameter and 80 mm altitude is resting with its base on HP and it is cut by a plane parallel to one of its generators and bisecting the axis. Draw the true shape of the section. Name the curve obtained.
b) A right regular pentagonal pyramid, edge of base 25 mm and height 60 mm is lying on one of its triangular faces on HP, its axis parallel to the VP. The pyramid is cut by a horizontal cutting plane at distance 20 mm from highest point of pyramid. Draw the development of all surfaces of resulting solid. [12+13]
- 5.a) A vertical cylinder of 60 mm diameter is completely penetrated by another cylinder of 45 mm diameter, their axes bisecting each other at right angles. Draw their projections showing curves of penetration, assuming the axis of the penetrating cylinder to be parallel to V.P.
b) A vertical cylinder of 75 mm diameter is penetrated by a cone base 75 mm diameter and axis 110 mm long, the two axes bisecting each other at right angles. Draw the front view showing lines of intersection. [13+12]

6.a) Draw i) Front view, ii) top view and iii) side view in third angle projection as shown in figure 1. All dimensions in mm.

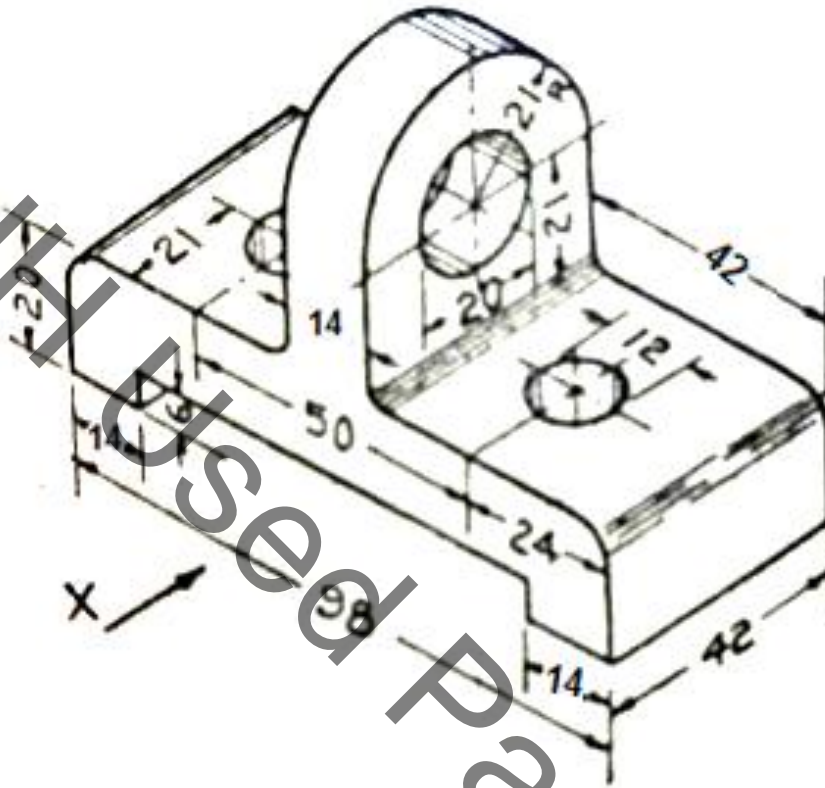

Figure 1

b) Draw i) Front view, ii) top view and iii) side view as shown in figure 2 from the left in First angle projection. All dimensions in mm. [13+12]

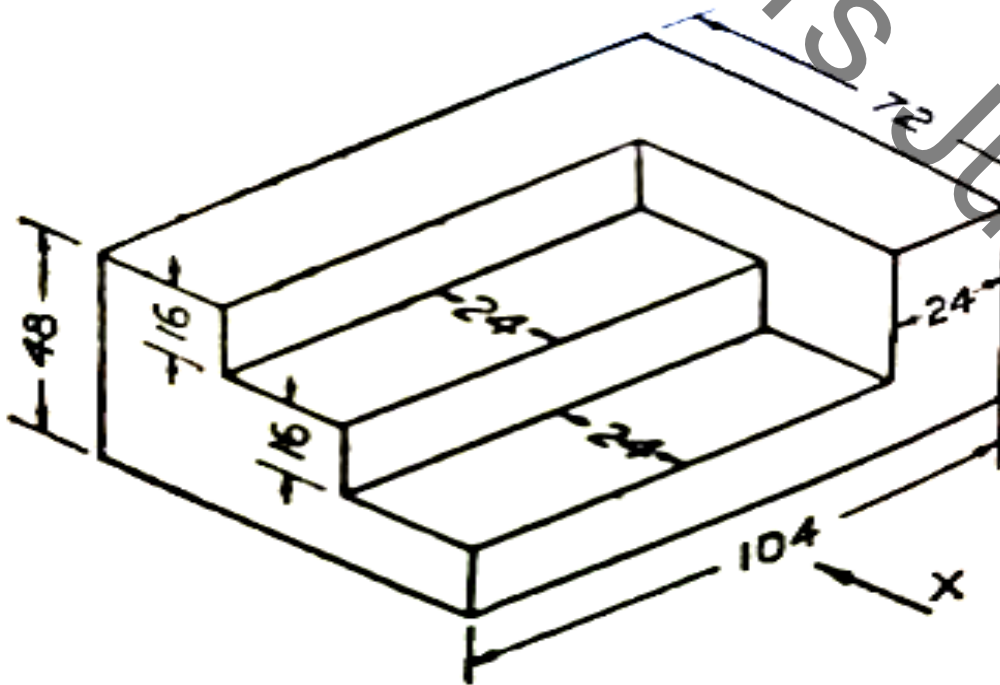

Figure 2