

Code No: 51015

JAWAHARLAL NEHRU TECHNOLOGICAL UNIVERSITY HYDERABAD

B.Tech I Year Examinations, May/June - 2019

ENGINEERING DRAWING

(Common to IT, AME)

Time: 3 hours

Max. Marks: 75

Answer any five questions
All questions carry equal marks

- 1.a) Draw a hyperbola having its two asymptotes inclined at 70° to each other and passing through a point P at a distance of 30 mm from one asymptote and 36 mm from the other. Draw a normal and a tangent at any convenient point.
- b) Construct a diagonal scale of R.F = $1/(2.5 \times 10^6)$ to read up to a single kilometer and long enough to measure 400 km. Mark a length of 254 km on it. [7+8]
2. A line AB, inclined at 45° to the V.P., has a 60 mm long front view. The end A is 10 mm from both the principal planes while the end B is 45 mm above the H.P. Draw the projections of the line and determine its true length and inclinations with the principal planes. Also, locate its traces. [15]
3. A semi-circle plate of 90 mm diameter has its straight edge on V.P. and inclined at 30° to H.P., while the surface of the plate is inclined at 45° to V.P. Draw the projections of the plate. [15]
4. A cylinder of 50 mm diameter and 70 mm long, is resting on one of its bases on H.P. It is cut by a section plane, inclined at 60° with H.P. Passing through a point on the axis at 15 mm from one end. Draw the three views of the solid and also obtain the true shape of the section. [15]
5. A Vertical cylinder of 60 mm diameter, is penetrated by another cylinder of 45 mm diameter. The axes of the two cylinders are intersecting at right angle. Draw the projections of the two cylinders, showing the lines (curves) of intersection. [15]
6. A sphere of radius 20 mm is kept on the top face of a square prism of side of base 40 mm and height 20 mm. The latter is placed on the top face of a cylinder of 65 mm diameter and 25 mm height. All the three solids have the common axis. Draw the isometric projection of combination of solids. [15]

7. Draw the following views of the object shown in figure. All dimensions are in mm.
 a) Front view b) Top view c) Side view from right. [5+5+5]

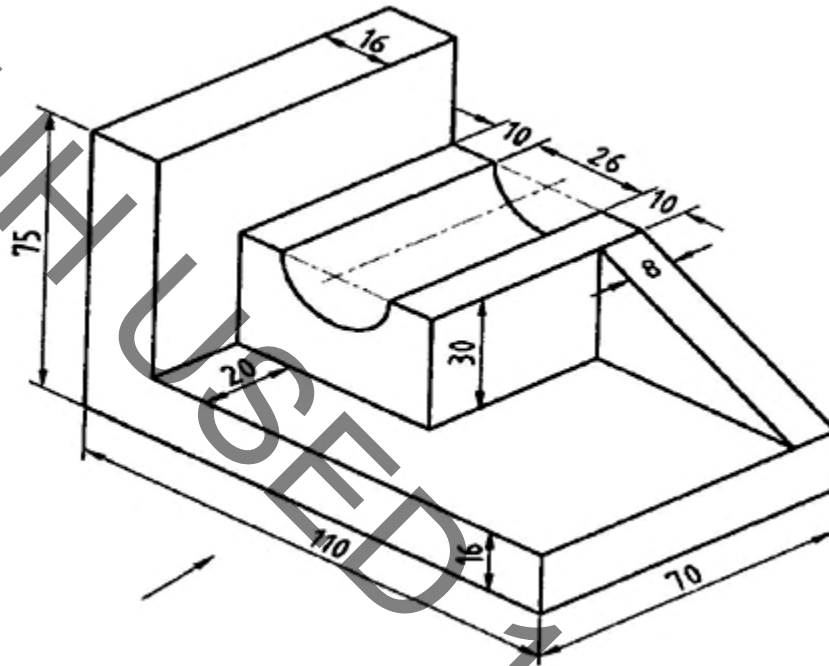

8. Draw the perspective view of a square plane with a 40 mm side resting on the G.P with one of its corners touching P.P. and a side right to the corner inclined at 45° to it. The station point is 65 mm in front of P.P, 60 mm above G.P. and lies in a C.P. which is 30 mm towards right of the corners touching the P.P. [15]

---ooOoo---

15-06-2019AM